

Unit Dimensions

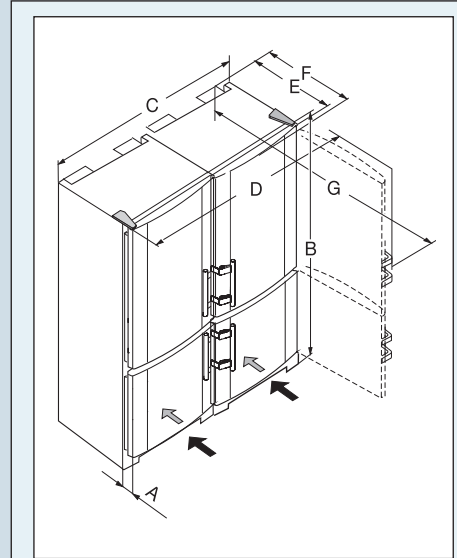

- A. 2-7/32" (56.5 mm)
- B. 79-3/16" (2011 mm)
- C. 47-3/4" (1212 mm)
- D. 49" (1244 mm)
- E. 24-1/8" (613 mm)
- F. 24-3/4" (629 mm)
- G. 46-9/16" (1182 mm)

Ventilation Requirements

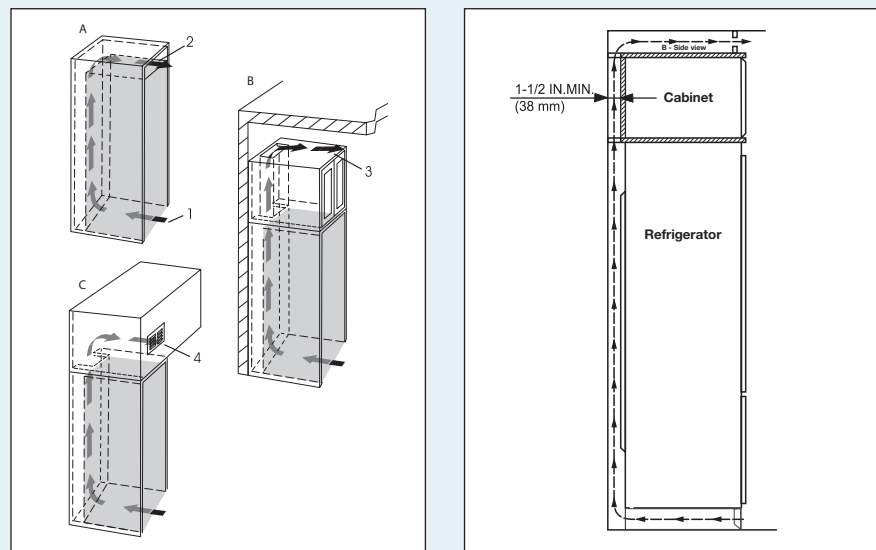

This type of cabinet must be carefully constructed using the correct dimensions and it must provide suitable ventilation to ensure proper appliance operation.

**Kitchen Cabinet Airflow**

The following ventilation dimensions must be observed: There must be a ventilation space at least 31 in.<sup>2</sup> (200 cm<sup>2</sup>) per appliance at the airflow inlet (1) and at the airflow outlet (2).

The top ventilation space can be directed in one of the following ways:

- A) Directly over the appliance (2) with a gap between the ceiling of the unit and the cabinet.
- B) Above the cabinet and below the ceiling (3).
- C) Through a vent installed in a soffit (4).

The refrigerator is designed to allow proper air flow when the appliance is installed up against the wall. A minimum space of 1 1/2" (38mm) is required behind any cabinet above the appliance if ventilating above that cabinet.

Cabinet Opening Dimensions

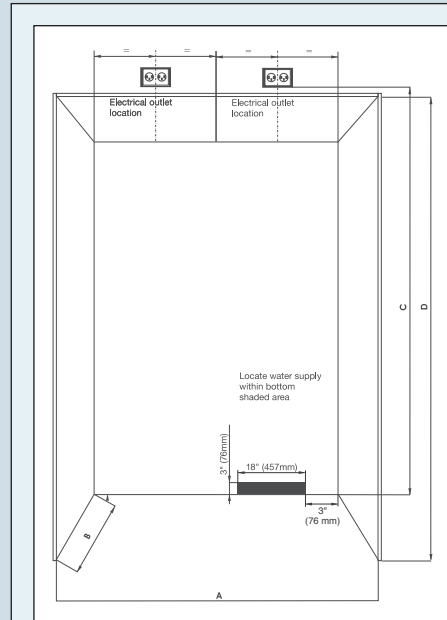

The appliance can be integrated into the kitchen units. To adapt the appliance to the height of the row of kitchen units, a suitable top cupboard can be fitted above the appliance.

**Unit Venting**

DO NOT restrict the air flow. A cross-sectional air flow of at least 31" square (200cm<sup>2</sup>) must be provided. The opening can either be directly over the appliance or behind of the cabinet on top of the unit (see ventilation requirements).

The CS models can be installed in standard 24" (609mm) deep cabinets. You will only have to make sure that the door swing clearance is enough. It is possible to push all CS models to the rear wall of the cabinet without modification.

When installing the appliance next to a wall, a distance on the hinge side of 1 13/32 inches (36 mm) minimum is required between the appliance and the wall to allow for the door handle projection when the door is open.

Minimum Cabinet Opening Dimensions:

- A. 47-3/4" (1212 mm)
- B. 24" (609 mm)
- C. 85-29/32" (2182 mm)
- D. CS 13.. 80" (2032 mm)\*

\*The given cabinet opening height dimension includes space for top air vent. If you choose to place the vent above the cabinet or in a soffit, you will need to adjust the height dimensions accordingly. Please refer to Ventilation Requirements.

Top Door Hinge Clearance

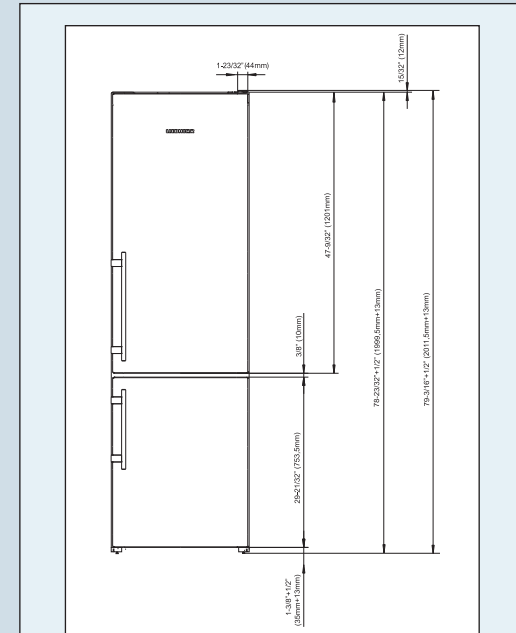

When installing CS units into a row of cabinets or wall units: Use these dimensions to achieve a custom look with the cabinetry while providing the necessary clearance for the top door hinge.



**Liebherr SBS 26S2**  
Freestanding/Semi Built-in



**LIEBHERR**  
Quality, Design and Innovation

The 48" Side-by-Side combination **SBS 26S2** joins flexibility with sleek design. Thanks to its stainless steel side walls, the SBS 26S2 can be featured as the centerpiece of your kitchen, or can be semi built-in into your kitchen cabinetry. With the SBS 26S2, you can achieve a flushed, built-in look with a freestanding unit without the added steps and cost of built-in installation.

Composed of two ENERGY STAR® rated bottom-freezer combination refrigerators **CS 1321** and **CBS 1360**, the SBS 26S2 provides flexible storage solutions within 4 full doors and 5 temperature zones. The SBS 26S2 includes unique features such as BioFresh technology, which helps food retain their healthy vitamins, aroma and appetizing appearance significantly longer than in conventional refrigerators. Energy efficient LED lighting takes a starring role by illuminating the main compartments, and a unique integrated LED lights sit on the bottom of the refrigerator door to shine down into freezer drawers when opened. Features such as a GlassLine shelving, bottle shelving, and stainless back wall make the interior of the unit as appealing as the beautiful exterior's ergonomic handles, beveled edges, and easy-to-clean SmartSteel finish.



Freestanding/Semi Built-in

Energy consumption

in 365 days kWh  
Estimated Yearly Energy Cost in US \$

Capacity

Total capacity cu.ft. (l)  
Refrigerator comp. cu.ft. (l)  
BioFresh comp. cu.ft. (l)  
NoFrost Freezer comp. cu.ft. (l)

Shipping weight lbs. (kg)

Climate rating

Sound rating dB(A)

Ice cube output lbs. (kg) / 24h

Ice cube stock lbs. (kg)

Door hinges

Outside dimensions

in inches (cm) H/W/D

Cut out dimensions

in inches (cm) H /W/D

Energy supply

Voltage V/Hz

SBS 26S2  
Premium



976
117*
29.7 (848)
21.3 (606)
7.3 (206)
8.5 (242)
482.8 (219)
SN-T
40**
3.1 (1.4)
4.4 (2.0)
left, reversible/right, reversible
79 9/16"/47 3/4"/24 13/16" (202/121.2/63)
80"/47 3/4"/24" (203.2/121.2/60.9)
115/60

\* Energy Cost will depend on utility rates and use. Estimated energy cost based on a national average electricity cost of 12 cents per kWh.

\*\* Noise output – according to EN 60704-3



**German Engineering:** Our superior products offer premium quality, cutting edge design and innovative features that fit your busy lifestyle. Exclusive components and materials, along with the latest production processes, ensure energy efficiency and performance for years to come.



**SuperCool/SuperFrost:** Simply quick chill and/or freeze fresh groceries to preserve optimum freshness and seal in flavors, textures as well as maintain essential vitamins and minerals.



**SmartSteel:** Available on select freestanding/semi built-in models, SmartSteel significantly reduces the visibility of fingerprints and is very easy to clean and scratch resistant. All that is required to maintain this beautiful exterior is the wipe of a clean dry or damp cloth.



**Energy Star:** Liebherr refrigerators help produce less energy waste and greenhouse gas emissions with the goal of having the least damaging effect on the environment, while offering solutions that help consumers conserve energy.



**SuperQuiet:** Noise is kept to a minimum with virtually silent, speed controlled compressors and a low-noise cooling circuit; while also ensuring exact performance, energy efficiency and SuperQuiet operation.



**Stainless back wall:** The high-quality, stainless back wall is both eye-catching and highly functional. The stainless wall prevents foods from freezing up against the evaporator, ensuring that the back of the refrigerator is always drip and ice-free. Ventilation slits also help guarantee optimum temperature distribution.



**BioFresh:** BioFresh guarantees the perfect climate for super-long-term freshness. Each drawer can be used individually and provides ideal humidity – HydroSafes with high humidity or DrySafes with low humidity – for a versatile storage solution of meats and cheeses as well as fruits and vegetables.



**SoftSystem:** Unique to Liebherr is our patented SoftSystem, often used in high-end cabinetry, ensures that the door closes gently, even when fully loaded. Plus the door opening angle can be reduced to 90 degrees allowing for more design options within kitchen décor.

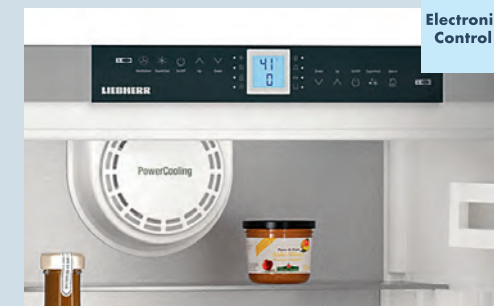

**Electronic Display:** Our intuitive electronic touch control panel ensures all functions are easy and convenient to use as well as guarantees that the settings selected remain accurate and constant.